

COMBINATION AIR VALVE

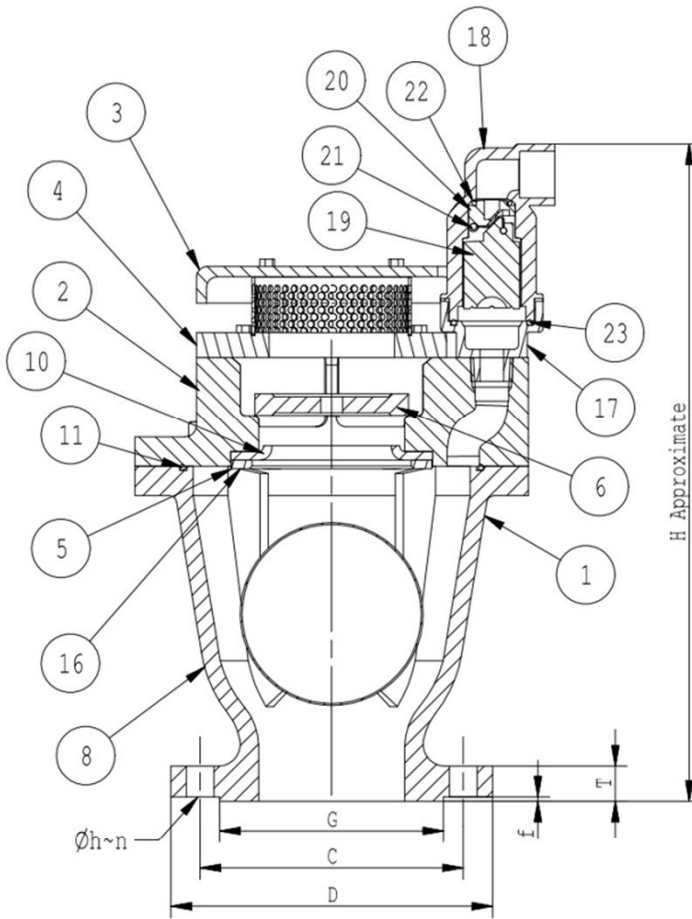

23	Oring B	EPDM		1
22	KINETIC SEAL	EPDM		1
21	FLOAT SEAL	EPDM		1
20	KINETIC FLOAT	Polypropylene		1
19	FLOAT B	Polypropylene		1
18	BODY B	Cast Iron	A 126 Class B	1
17	BASE	Cast Iron	A 126 Class B	1
16	Seat Holder Bolt	SUS 304		4
15	Cover Bolt	Steel		4
14	Anti Shock Cover Bolt	Steel		4
13	Bonnet NUT	Steel		4
12	Bonnet Bolt	Steel		4
11	O-RING	EPDM		1
10	SEAL RING	EPDM		1
8	FLOAT	SUS 304	A 276 TYPE 304	1
7	SCREEN	SUS 304	A 276 TYPE 304	1
6	Anti Shock Plate	Aluminum		1
5	SEAT HOLDER	Brass	B 21	1
4	Anti Shock Cover	Cast Iron	A 126 Class B	1
3	COVER	Cast Iron	A 126 Class B	1
2	BONNET	Cast Iron	A 126 ClassB	1
1	BODY	Cast Iron	A126 Class B	1
PC NO	PART NAME	Material	DESIGNATION	QTY

*** REMARK : Anti Shock is an option

SIZE	øD	øC	øG	f	T	øh~n	H
50	165	125	50	3	20	19~4	310
80	200	160	80	3	22	19~8	390
100	220	180	100	3	25	19~8	455
150	285	240	150	3	26	23~8	574
200	340	295	200	3	28	23~8	720



CHAIPONG ENGINEERING CO.,LTD.

Tel : 02-482-1526-7 Fax : 02-019-8911

email : chaipong_cpe@hotmail.com