

Y-STRAINER

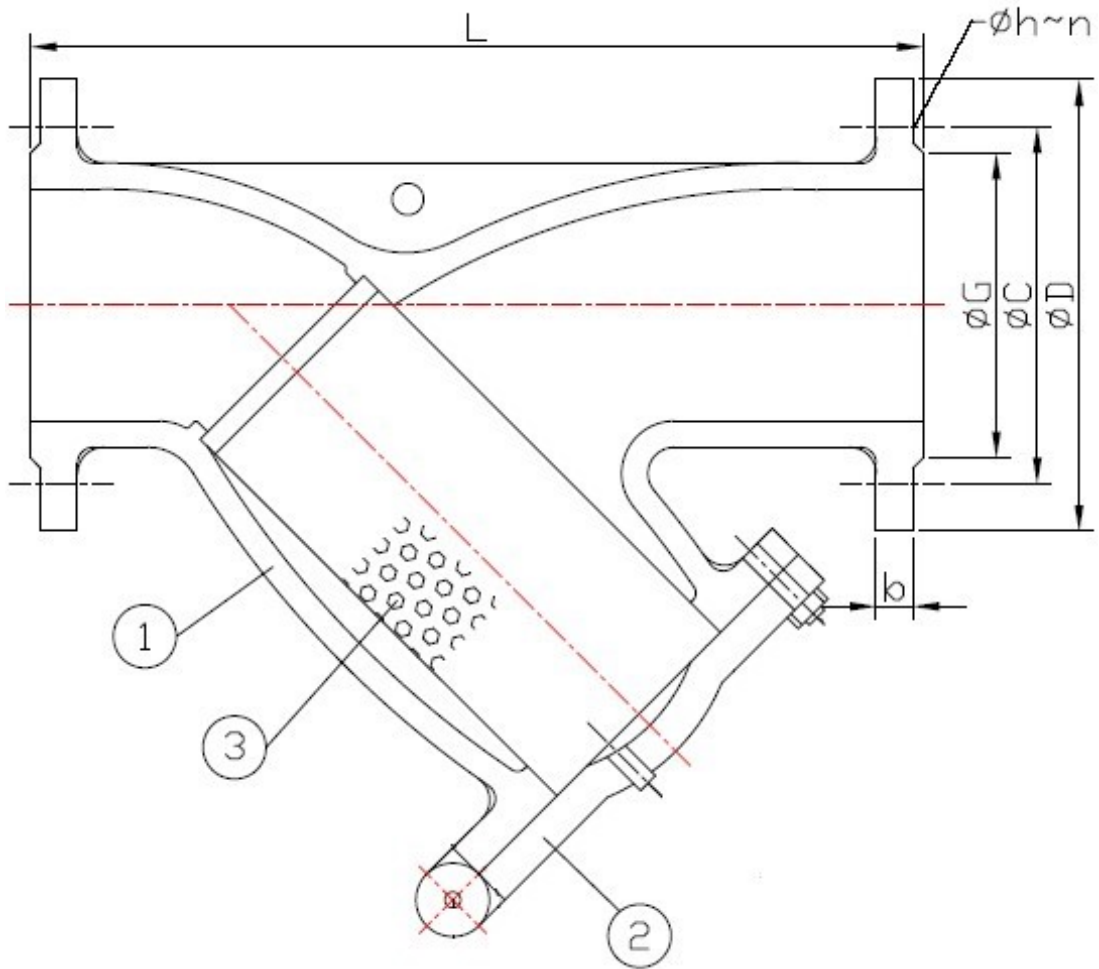

Size	L	FLANGE DIMENSIONS						
		ØD	ØC	ØG	Øh	n	f	b
100	370	220	180	156	18	8	3	21
150	490	285	240	211	22	8	3	23
200	570	340	295	266	22	8	3	23
250	680	395	350	319	22	12	3	25
300	800	445	400	365	22	12	3	25
400	900	565	515	480	26	16	3	28
500	1000	670	620	582	26	20	3	30
600	1100	780	725	682	30	20	3	31
700	1200	895	840	749	30	24	3	35
800	1300	1015	950	901	33	24	3	39
900	1400	1115	1050	1001	33	28	3	41
1000	1500	1230	1160	1112	36	28	3	45



* T-Strainer also available

No.	PART NAME	MATERIAL	REFERENCE
1	Body	Cast Iron	A 126 Class B
2	Cover	Cast Iron	A 126 Class B
3	Strainer	Stainless Steel	A 276 Type 304



CHAIPONG ENGINEERING CO.,LTD.

Tel : 02-482-1526-7 Fax : 02-019-8911

email : chaipong_cpe@hotmail.com