

GATE VALVE

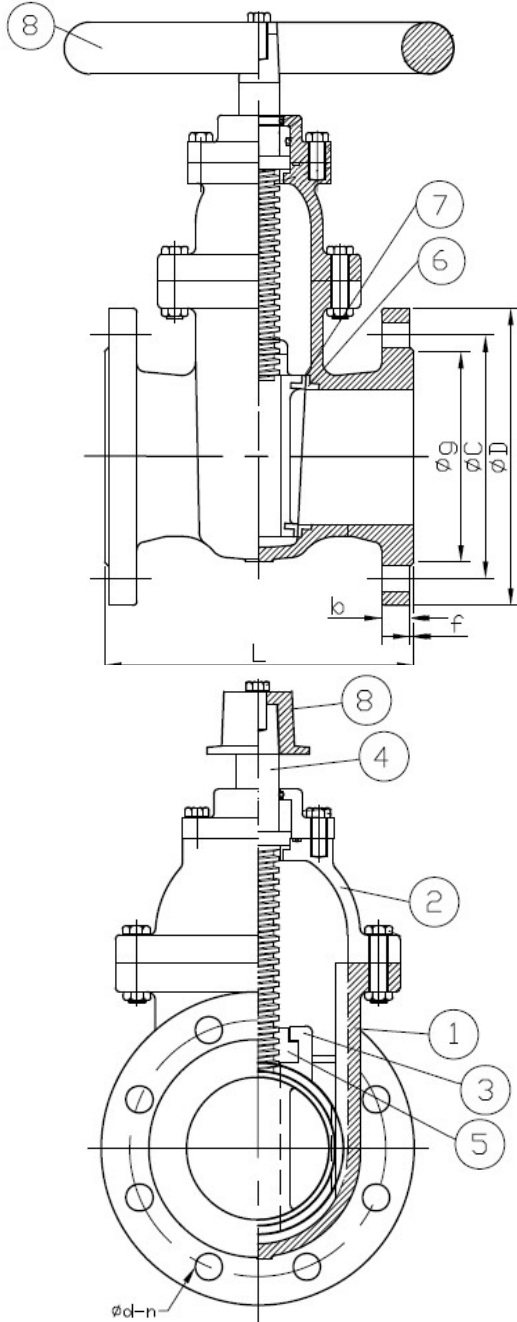

Size	L	FLANGE DIMENSIONS						
		ØD	ØC	ØG	Øh	n	f	b
80	203	200	160	132	18	8	3	19
100	229	220	180	156	18	8	3	21
150	267	285	240	211	22	8	3	23
200	292	340	295	266	22	8	3	23
250	330	395	350	319	22	12	3	25
300	356	445	400	365	22	12	4	25
400	406	565	515	480	26	16	4	28
500	457	670	620	582	26	20	4	30
600	508	780	725	682	30	20	5	31
700	610	895	840	749	30	24	5	35
800	660	1015	950	901	33	24	5	39
900	711	1115	1050	1001	33	28	5	41
1000	811	1230	1160	1112	36	28	5	45



No.	PART NAME	MATERIAL	REFERENCE	Q' TY
1	Body	Ductile Iron/Cast Iron	A 536 Grade 65/A 126 Class B	1
2	Bonnet	Ductile Iron/Cast Iron	A 536 Grade 65/A 126 Class B	1
3	Disc	Ductile Iron/Cast Iron	A 536 Grade 65/A 126 Class B	1
4	Stem	Stainless Steel/Bronze	A 276 Type 304/B 21	1
5	Stem Nut	Bronze	B 62	1
6	Body Seat Ring	Bronze	B 62	1
7	Disc Seat Ring	Bronze	B 62	1
8	Hand wheel or Cap	Cast Iron	A 126 Class B	1



CHAIPONG ENGINEERING CO.,LTD.

Tel : 02-482-1526-7 Fax : 02-019-8911

email : chaipong_cpe@hotmail.com