

FOOT VALVE

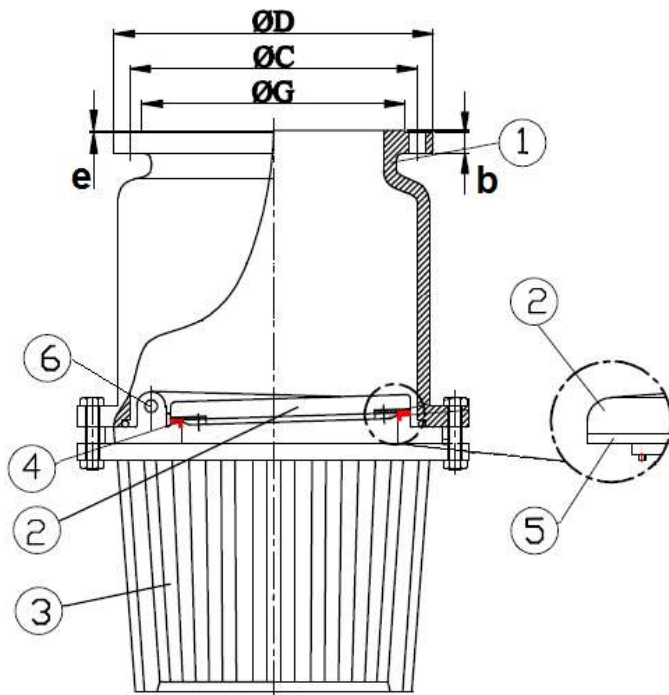

Size	ØD	ØC	ØG	øh	n	e	b
80	200	160	132	18	8	3	19
100	220	180	156	18	8	3	21
150	285	240	211	22	8	3	23
200	340	295	266	22	8	3	23
250	395	350	319	22	12	3	25
300	445	400	365	22	12	4	25
350	505	460	472	23	16	4	28
400	565	515	480	26	16	4	28
500	670	620	582	26	20	4	30
600	780	725	682	30	20	5	31

No.	PART NAME	MATERIAL	REFERENCE	Q' TY
1	Body	Ductile Iron/Cast Iron	A 536 Grade 65/A 126 Class B	1
2	Disc	Ductile Iron/Cast Iron	A 536 Grade 65/A 126 Class B	1
3	Strainer	Ductile Iron/Cast Iron	A 536 Grade 65/A 126 Class B	1
4	Body Seat Ring	Bronze	B 62	1
5	Disc Seat Ring	Rubber (NBR)	D2000	1
6	Hinge Pin	Stainless Steel	A 276 Type 304	1



CHAIPONG ENGINEERING CO.,LTD.

Tel : 02-482-1526-7 Fax : 02-019-8911

email : chaipong_cpe@hotmail.com