

KNIFE GATE

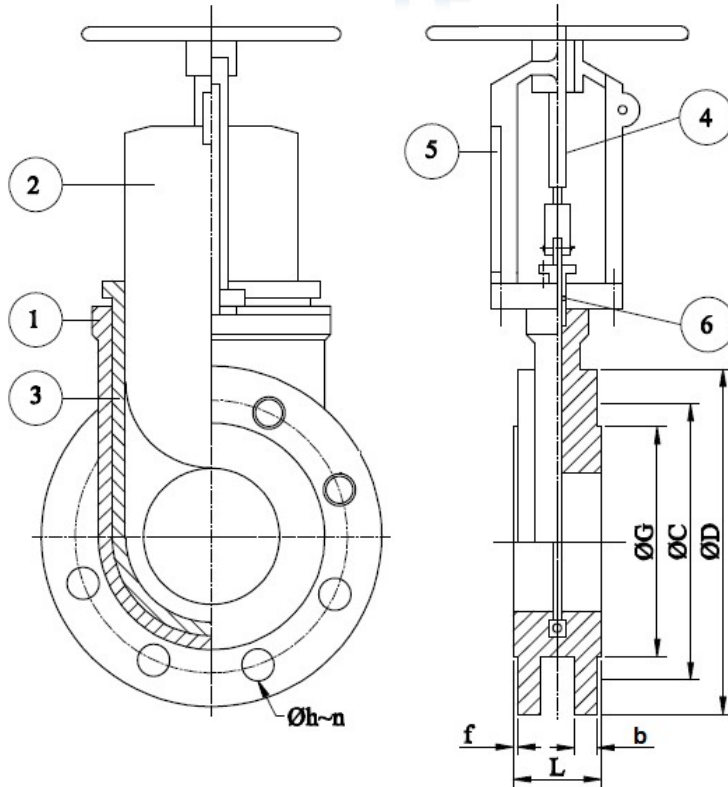

Size	L	FLANGE DIMENSIONS						
		ØD	ØC	ØG	Øh	n	f	b
80	51	200	160	132	18	8	3	19
100	51	220	180	156	18	8	3	21
150	57	285	240	211	22	8	3	23
200	70	340	295	266	22	8	3	23
250	70	395	350	319	22	12	3	25
300	76	445	400	365	22	12	3	25
400	89	565	515	480	26	16	3	28
500	114	670	620	582	26	20	3	30
600	114	780	725	682	30	20	3	31
700	140	895	840	749	30	24	3	35
800	140	1015	950	901	33	24	3	39
900	170	1115	1050	1001	33	28	3	41
1000	170	1230	1160	1112	36	28	3	45

No.	PART NAME	MATERIAL	REFERENCE
1	Body	Ductile Iron/Cast Iron	A 536 Grade 65/A 126 Class B
2	Disc	Stainless Steel	A 276 Type 304
3	Body Seat Ring	Rubber (NBR)	D2000
4	Stem	Stainless Steel	A 276 Type 304
5	Yoke	Ductile Iron/Cast Iron	A 536 Grade 65/A 126 Class B
6	Packing	Asbestos	-



CHAIPONG ENGINEERING CO.,LTD.

Tel : 02-482-1526-7 Fax : 02-019-8911

email : chaipong_cpe@hotmail.com