

CHECK VALVE

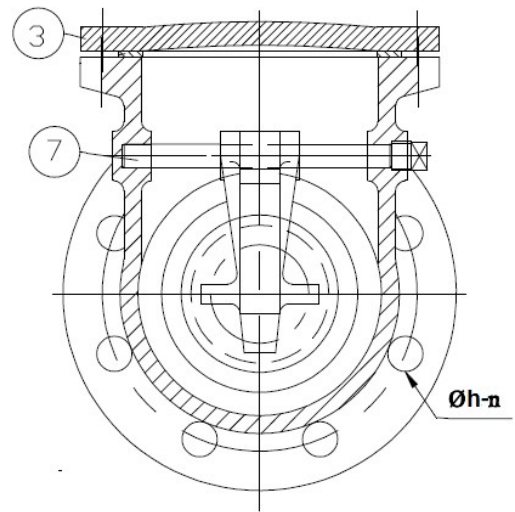

Size	L	FLANGE DIMENSIONS						
		ØD	ØC	ØG	Øh	n	f	b
80	241	200	160	132	18	8	3	19
100	292	220	180	158	18	8	3	21
150	356	285	240	212	22	8	3	23
200	495	340	295	268	22	8	3	23
250	622	395	350	320	22	12	3	25
300	698	445	400	370	22	12	4	25
400	914	565	515	482	26	16	4	28
500	1067	670	620	585	26	20	4	30
600	1219	780	725	682	30	20	5	31
700	1448	895	840	749	30	24	5	35
800	1680	1015	950	901	33	24	5	39
900	1919	1115	1050	1004	33	28	5	41
1000	2250	1230	1160	1112	36	28	5	45

No.	PART NAME	MATERIAL	REFERENCE	Q' TY
1	Body	Ductile Iron/Cast Iron	A 536 Grade 65/A 126 Class B	1
2	Disc	Ductile Iron/Cast Iron	A 536 Grade 65/A 126 Class B	1
3	Cover	Ductile Iron/Cast Iron	A 536 Grade 65/A 126 Class B	1
4	Body Seat Ring	Bronze	B 62	1
5	Disc Seat Ring	Rubber (NBR)	D2000	1
6	Disc Seat Holder	Stainless Steel	A 276 Type 304	1
7	Hinge Pin	Stainless Steel	A 276 Type 304	1

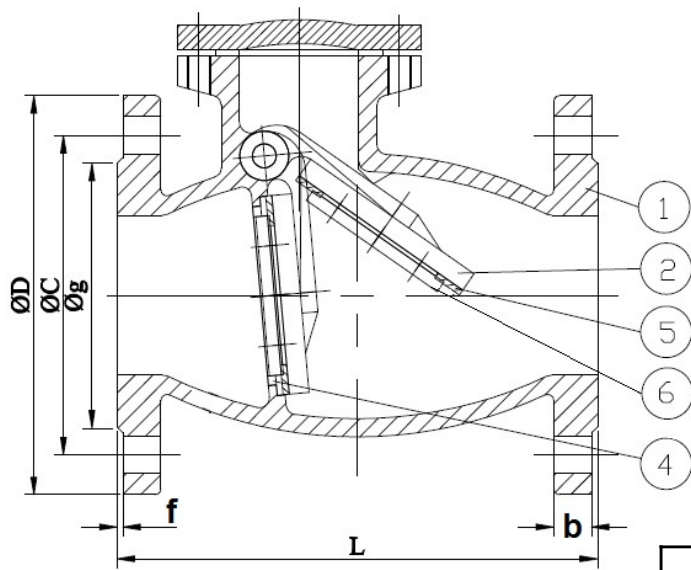

CHAIPONG ENGINEERING CO.,LTD.

Tel : 02-482-1526-7 Fax : 02-019-8911

email : chaipong_cpe@hotmail.com