

# BUTTERFLY CHECK VALVE

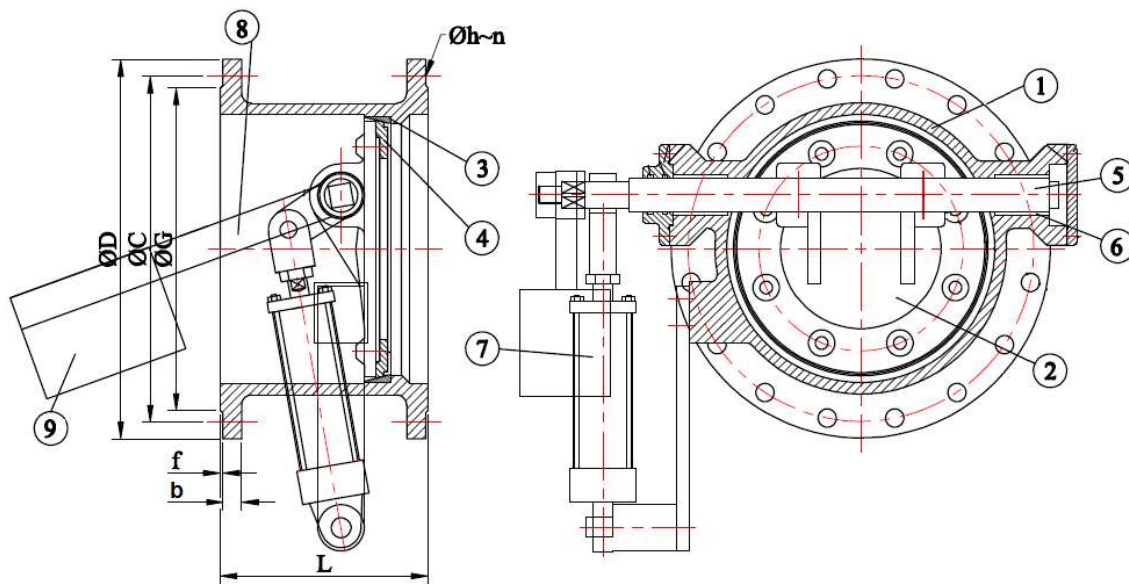

Size	L	FLANGE DIMENSIONS						
		ØD	ØC	ØG	Øh	n	f	b
100	190	220	180	158	18	8	3	21
150	210	285	240	212	22	8	3	23
200	230	340	295	268	22	8	3	23
250	250	395	350	320	22	12	3	25
300	270	445	400	370	22	12	4	25
400	310	565	515	482	26	16	4	28
500	350	670	620	585	26	20	4	30
600	390	780	725	682	30	20	5	31
700	430	895	840	749	30	24	5	35
800	470	1015	950	901	33	24	5	39
900	510	1115	1050	1004	33	28	5	41



No.	PART NAME	MATERIAL	REFERENCE	Q' TY
1	Body	Ductile Iron/Cast Iron	A 536 Grade 65/A 126 Class B	1
2	Disc	Ductile Iron/Cast Iron	A 536 Grade 65/A 126 Class B	1
3	Body Seat Ring	Stainless Steel	A 276 Type 304	1
4	Disc Seat Ring	Stainless Steel	A 276 Type 304	1
5	Shaft	Stainless Steel	A 276 Type 304	1
6	Bushing	Bronze	B 62	2
7	Oil Dash Pot	-	-	1 set
8	Wight Arm	Steel	SS 400	1
9	Wight	Cast Iron	A 126 Class B	1



**CHAIPONG ENGINEERING CO.,LTD.**

Tel : 02-482-1526-7 Fax : 02-019-8911

email : chaipong\_cpe@hotmail.com