

Hydro Shell	20 bar
Hydro Valve Seat	10 bar
Hydro Back Seat	- bar
Air Seat	- bar
Stem	- bar
Working Pressure	10 bar
Test Pressure	10 bar

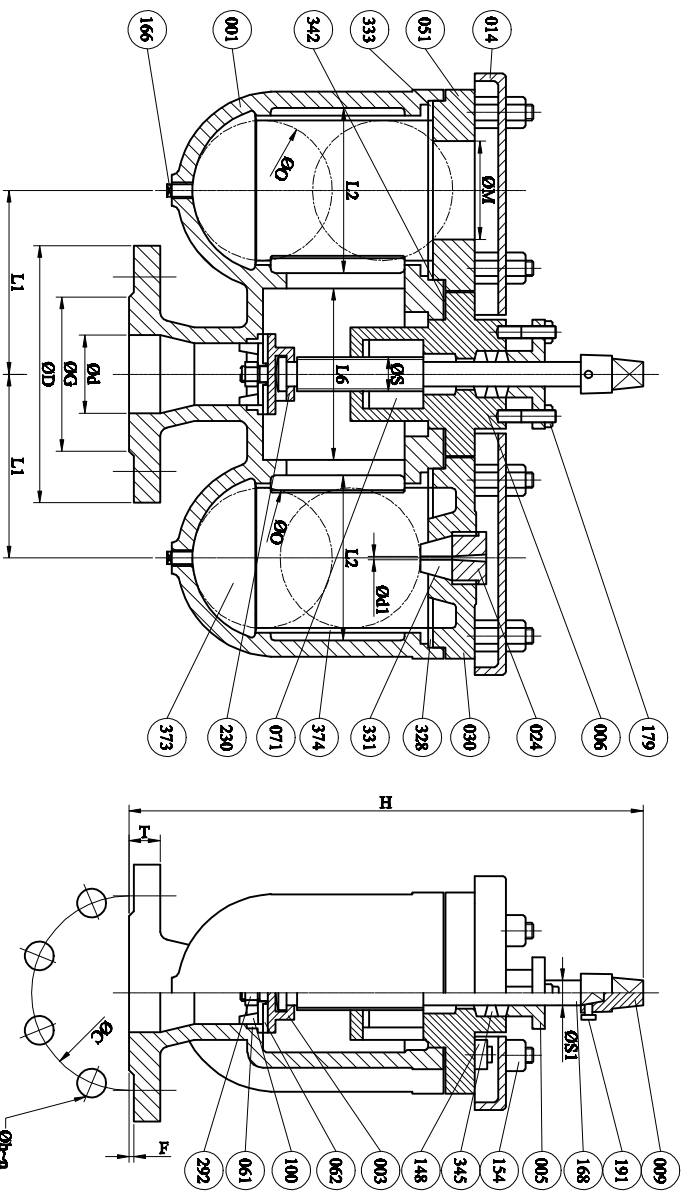

SIZE ØD	FLANGED BS. 4504 PN.10							ØS1	ØS2	Ød1	L1	L2	L3	L4	L5	L6	H	ØM	ØO	ØP
	ØD	ØC	ØG	Øh	n	T	F													
50	165	125	99	19	4	20	3	16	22	2.2	118	106	76	150	386	110	330	63	90	93
80	200	160	132	19	8	22	3	20	28	2.2	145	115	100	185	475	153	370	68	95	99
100	220	180	156	19	8	24	3	24	32	2.5	157	122	114	190	505	168	410	70	100	104
150	285	240	211	23	8	26	3	28	38	2.8	173	132	154	220	550	190	470	78	110	114

009	Cap	Cast Iron	TTS 1368	1
374	Float Guide	ABS	----	2
373	Float	ABS	----	2
345	Packing	Graphical Adhesive	----	1
342	Stuffing Box Gasket	Rubber (NBR)	BS 2494	1
333	Plate Seat	Rubber (NBR)	BS 2494	1
331	Small Orifice	Rubber (NBR)	BS 2494	1
328	Lid Gasket	Rubber (NBR)	BS 2494	1
292	Nut For Main Disc	Brass	TTS 1368	1
230	Split Pin	Brass	TTS 1368	1
191	Cop Bolt	Galvanized Steel	TTS 171	1
179	Gland Stud&Nut	Galvanized Steel	TTS 171	2
168	Stem	Stainless Steel	TTS 1368	1
166	Plug	Malleable Iron	TTS 171	2
154	Stud & Nut	Galvanized Steel	TTS 171	8
148	Stuffing Box Seal Nut	Galvanized Steel	TTS 171	4
100	Gland For Main Disc	Gunmetal	TTS 1368	1
071	Stem Nut	Gunmetal	TTS 1368	1
062	Disc Seat Ring	Rubber (NBR)	BS 2494	1
061	Body Seat Ring	Gunmetal	TTS 1368	1
051	Gland For Seat Cover	Cast Iron	TTS 1368	1
030	Lid	Cast Iron	TTS 1368	1
024	Seat Holder	Brass	TTS 1368	1
014	Cover	Cast Iron	TTS 1368	2
006	Stuffing Box	Cast Iron	TTS 1368	1
005	Gland	Cast Iron	TTS 1368	1
003	Disc	Gunmetal	TTS 1368	1
001	Body	Cast Iron	TTS 1368	1
NO.	PART	MATERIAL	DESIGNATION	QTY



CHAIPONGENGINEER CO.,LTD.

PROJECT : GENERAL

TITLE : DOUBLE AIR VALVE SIZE 50-150mm. PN.10

DRAWN BY : Boonsatuk SCALE : No Scale

DESIGNER : Boonsatuk DATE : 19-04-2006

CHECKER : DRAWING NO.

APPROVER : CPE-DAV50-150-01