

**มาตรฐาน ภาชนะทดสอบเหลว Liquid Epoxy ความหนา >250 ไมครอน
ภาชนะทดสอบก๊าซ Gas Test Epoxy ความหนา >200 ไมครอน**

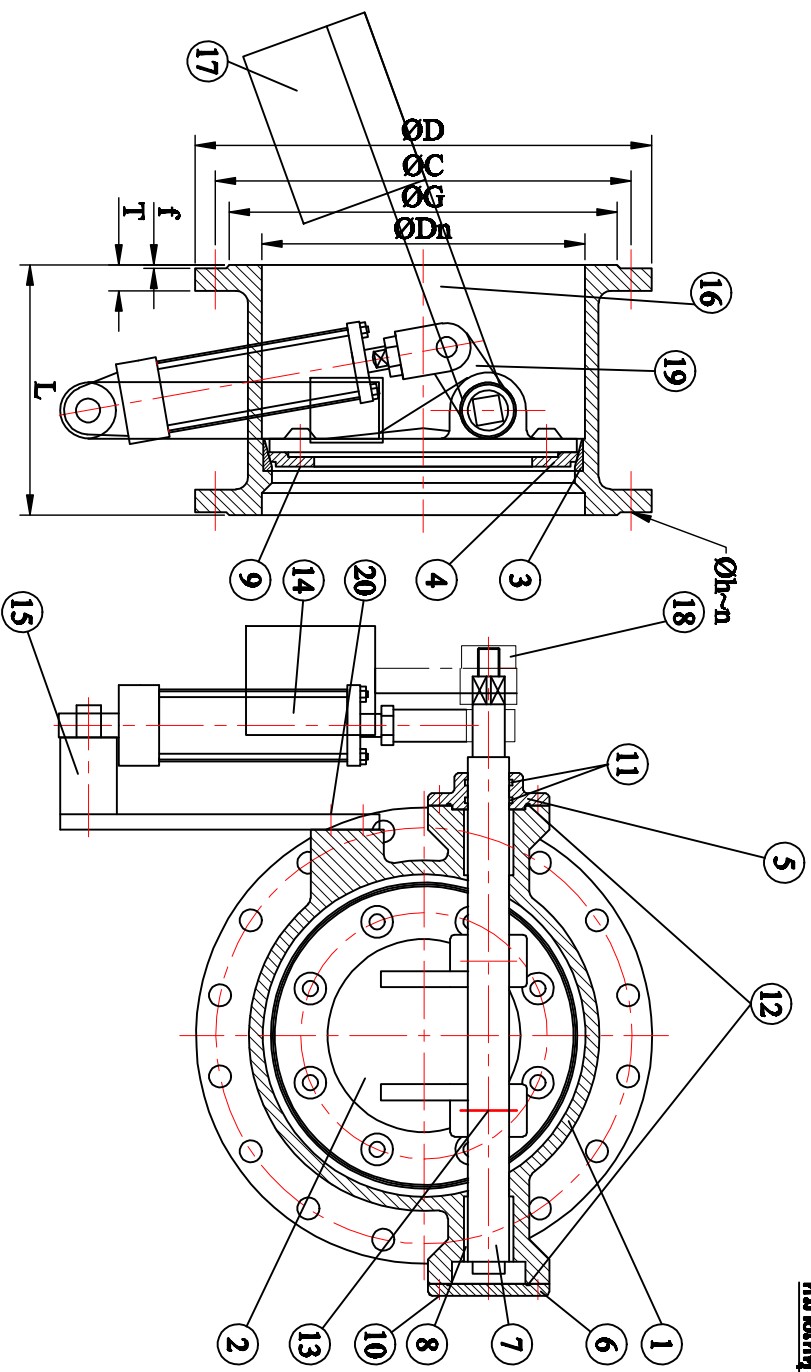

SIZE	L	FLANGE DIMENSIONS							
		ØD	ØC	ØG	Øh	n	t	f	
100	190	220	180	158	18	8	8	24	3
150	210	285	240	212	22	8	8	26	3
200	230	340	295	268	22	8	8	26	3
250	250	395	350	320	22	12	12	28	3
300	270	445	400	370	22	12	12	28	4
400	310	565	515	482	26	16	16	32	4
500	350	670	620	585	26	20	20	34	4
600	390	780	725	682	30	20	20	36	5
700	430	895	840	749	30	25	25	35	5
800	470	1015	950	901	33	24	24	39	5
900	510	1115	1050	1004	34	28	28	41	5

HYDROSTATIC TESTING	10 bar
WORKING PRESSURE	20 bar
BODY TESTING	10 bar
DISC TESTING	- bar
HYDRO BACK SEAT	- bar
AIR SEAT	- bar
STEM	- bar

20	Nut For Slay	Galvanized Steel	17100 St.37	4
19	Arm For Shaft	Steel	4190	1
18	Nut For Wight Arm	Galvanized Steel	17100 St.37	1
17	Wight	Steel	4190	1
16	Wight Arm	Steel	4190	1
15	Slay	Steel	4190	1set
14	Oil Dash Pot	-	-	1set
13	Shaft Pin	Stainless Steel	ASTM A276 Type 304	2
12	O-Ring B	Rubber (NBR)	2494	2
11	O-Ring A	Rubber (NBR)	2494	2
10	Nut For End Plate	Galvanized Steel	17100 St.37	8
9	Nut For Disc	Stainless Steel	ASTM A 126 Class B	8
8	Bushing	Bronze	ASTM B62	2
7	Shaft	Stainless Steel	ASTM A580 Gr. 420	1
6	End Plate B	Cast Iron	ASTM A 126 Class B	1
5	End Plate A	Cast Iron	ASTM A 126 Class B	1
4	Disc Seat Ring	Stainless Steel Laminating Steel	ASTM A473 Gr. 316	1
3	Body Seat Ring	Stainless Steel	ASTM A276 Type 304	1
2	Disc	Ductile Iron	ASTM A 536 Grade 64-45-12	1
1	Body	Cast Iron	ASTM A 126 Class B	1

CHAIPONG ENGINEERING CO.,LTD.

PROJECT : GENERAL

TITLE : BUTTERFLY CHECK VALVE Size 100-900 mm.

DRAWN BY : Boonsakul SCALE : No Scale

DESIGNER : Boonsakul DATE : 07-01-2014

CHECKER : DRAWING NO.

APPROVER : CPE-BCV100-900-01